



# SD250-SS

FRZERO<sup>50</sup> SHOWER DRAIN - FOR USE WITH MOLDED BASE

Project Name: \_\_\_\_\_

Project Number: \_\_\_\_\_

Fixture #

## Description:

**2" FR PVC Shower Drain for molded shower bases w/round Stainless Steel grate. Meets flame and smoke requirements of CAN/ULC S102.2-10 for non-combustible buildings (when approved PVC primer and solvent cement is used to make joints).**

### Certification



\*The "cSAus Meets UPC" mark means the product conforms to the requirements of the NPC, UPC, IPC and IRC.



CAN/ULC S102.2  
FSR 0 / SDC 40

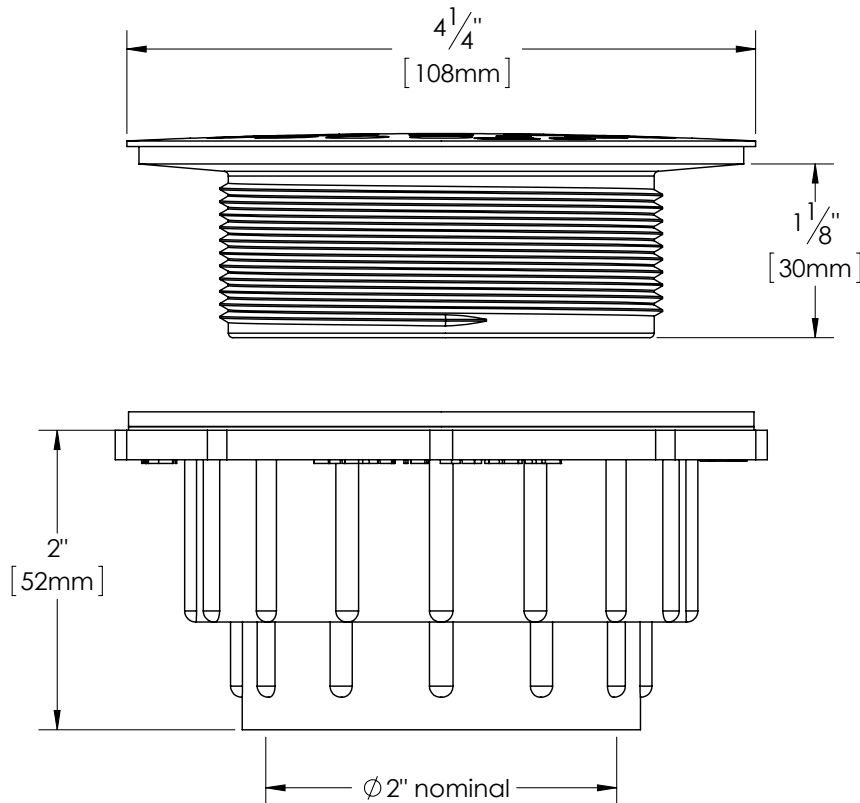

### Oakville Stamping and Bending Ltd.

2200 Speers Road, Unit C. Oakville, ON. Canada. L6L 2X8.

T. 905.827.0320 or toll free 1.877.314.6040 F. 905.827.6375 or toll free 1.877.827.6040.

All rights reserved. OS&B® reserves the right to change product specifications and material or discontinue models without notice.